

Elección de Vistas

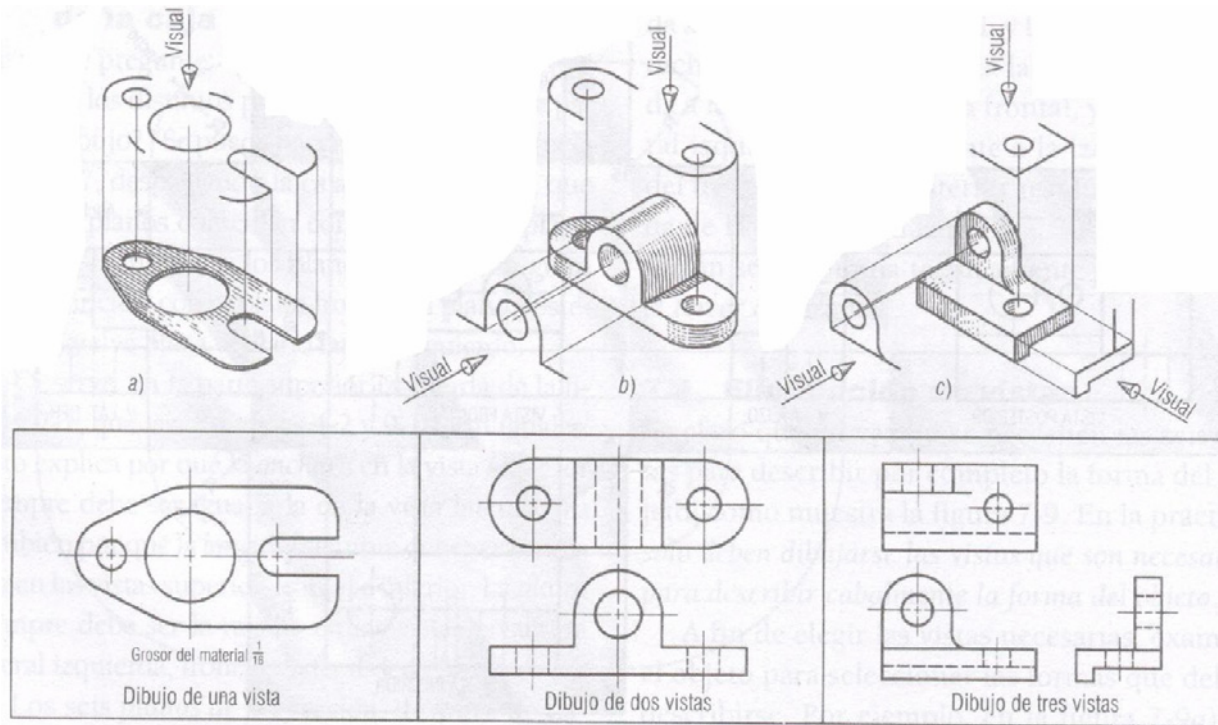

Vistas necesarias.

- Seleccionar las vistas mínimas necesarias para describir la pieza
- La vista frontal
 - Para elegir la Vista Frontal de la pieza que se va a dibujar:
 - Mostrar
 - o La mayor información
 - o El menor número de líneas ocultas
 - o La posición de trabajo
 - o La vista que mejor identificación inmediata proporcione
- Seleccionar las vistas que se distribuyan mejor sobre la hoja

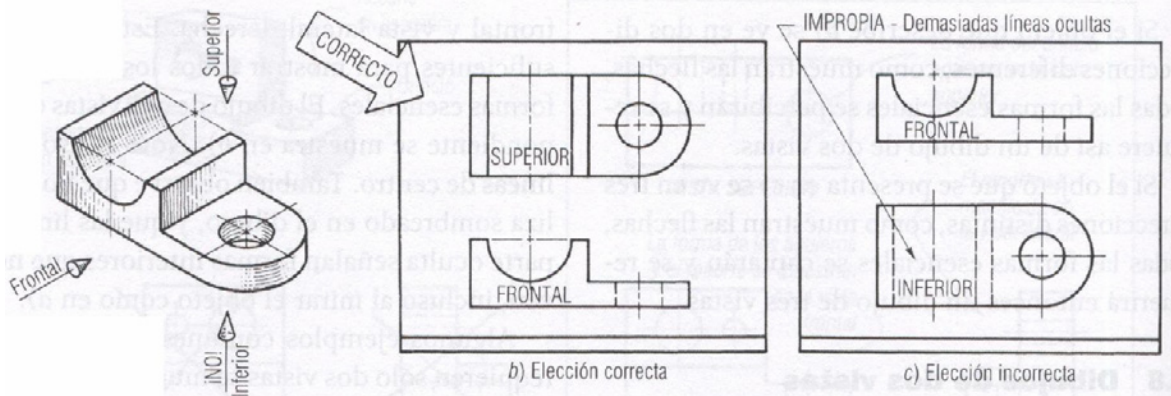

Vistas con el menor número de líneas no visibles.

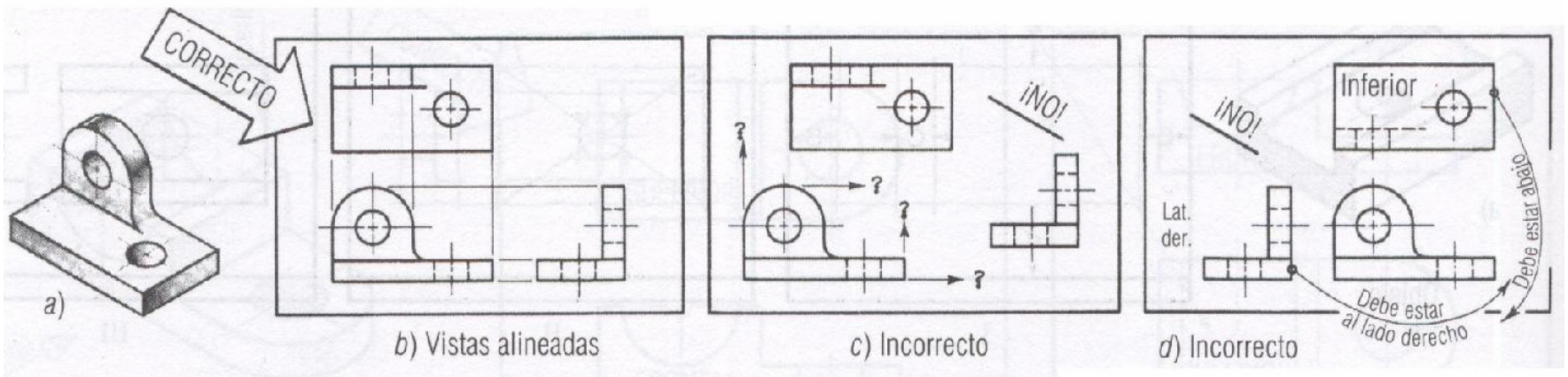

Disposición de las vistas.

Dos vistas de una brida de escape.

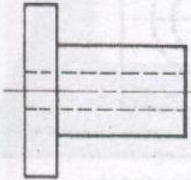
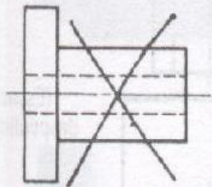
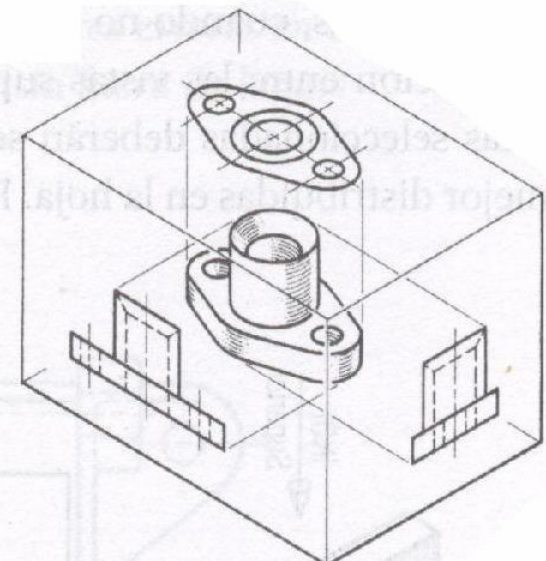
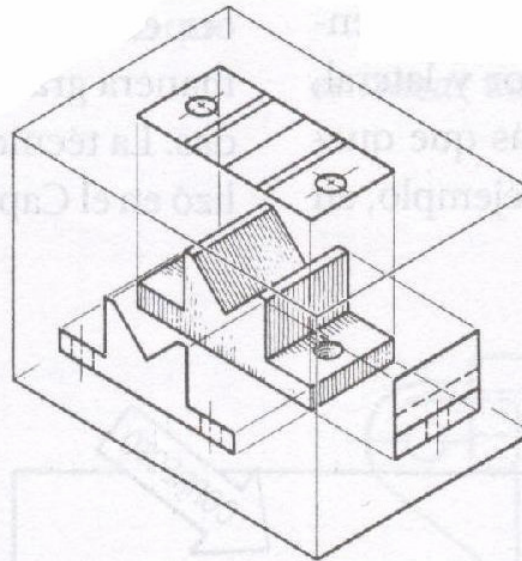

a)

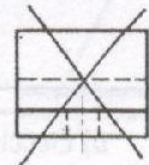
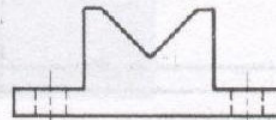
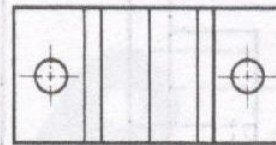

b)

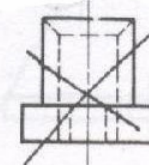
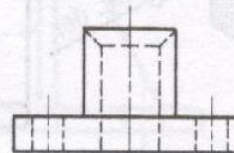
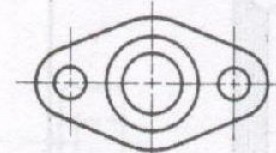

c)

Dibujos de dos vistas.

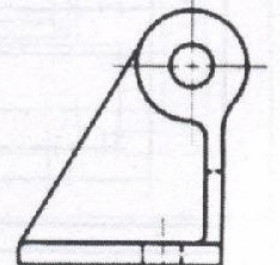
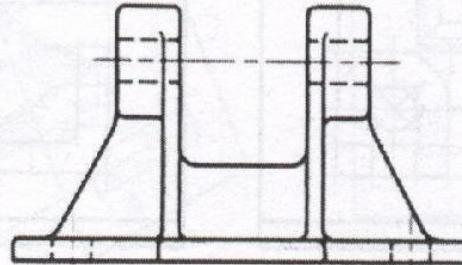
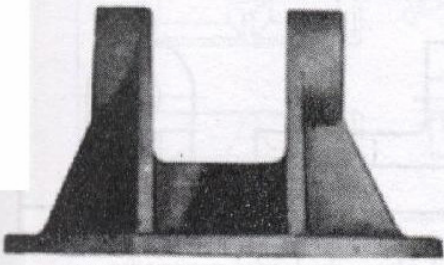
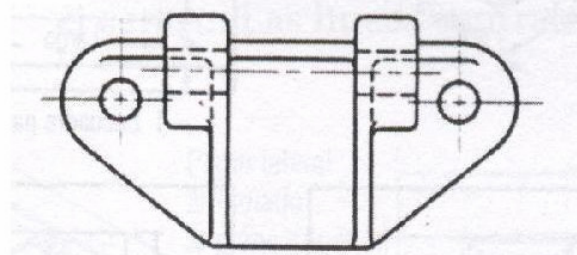
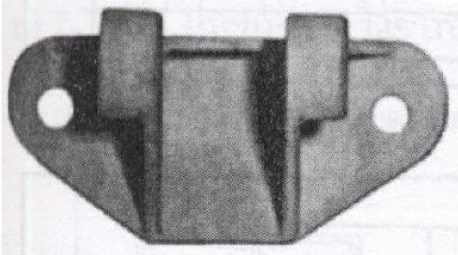

a) El objeto

b) El dibujo

Dibujo de tres vistas de una ménsula (soporte de eje).